

14 years  
World No. **1**\*

**JACK**

**A2C *FST***

**Full Speed Over Cross Joint**



**Vigorously Ape  
Platform Motor**



**Fortress Electric  
Control**

\*Source: Frost & Sullivan's research based on the number of industrial sewing machines sold by major global industrial sewing machine companies in each year between 2010 and 2023, market research completed in September 2024.

# FST Powerful Cross-seam System

Powered by the Mighty Ape Platform Motor, it provides strong piercing force and fabric feeding force, enabling the machine to cross seam portions and handle thick materials without speed reduction. The Fortress Electric Control ensures that the motor can work continuously and stably without being affected by the environment.

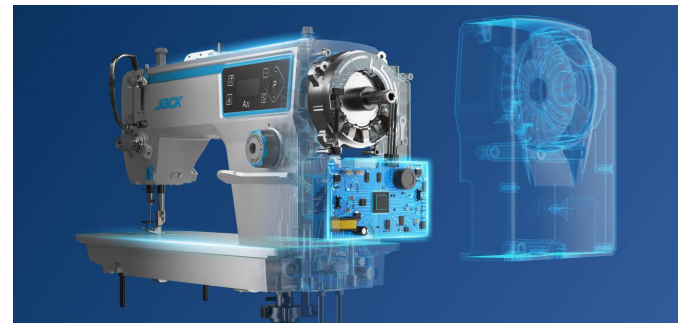
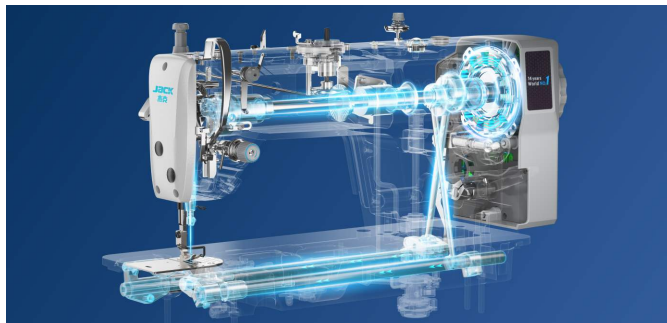
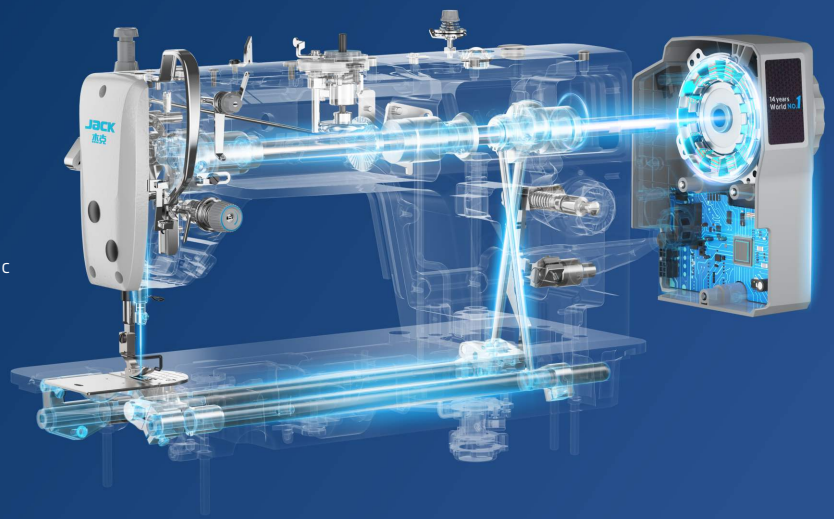

## • Mighty Ape Platform Motor :

High Torque, High Explosive Power  
5.5NM Ultra - large torque + Piercing force through 100 layers of paper.

## • Fortress Electric Control:

Strong Adaptability, Ultra - stability  
Adapts to an ultra - wide voltage range of 110 - 295V + Can withstand an electrostatic air voltage of 12000V.

## Customer Value

The ability to cross seam portions and handle thick materials is increased by **14%**

Overall efficiency is increased by **3.7%**

## Technical Parameters

Model	Needle	Thread number	Stitch length (mm)	Height of presser foot (mm)	Max. sewing speed (S.p.m)	Thin materials	Medium - thick materials	Thick materials	volume (mm)	Weight (kg)
A2C-C	DBx1 11-18#	2	5	1-13	5000	✓	✓		645x248x550	30/36.5
A2C-CH-7	DPx5 18-21#	2	7	1-13	3500			✓	645x248x550	30/36.5